

*mini*

SHALLOW PLOUGH

Maximum Profitability



# OVLAC

## 90 YEARS OF EXPERIENCE

### In tillage equipment

**Ovlac** is a **family-owned company** which has been manufacturing farming equipment since 1936. Since its beginnings, Ovlac has focused its activity in manufacturing mouldboard ploughs, which have been the company's flagship product for decades and still is today.

Over the last 15 years, the **Ovlac** product range has expanded to include other soil working tools such as Cultivators, Chisels and Short Disc Harrows. Today, Ovlac is being run by its third generation and its the biggest Spanish soil working equipment manufacturer.

**Ovlac** exports around 60% of its production to more than 20 countries.

Competitive and demanding markets such as France, Germany and the United Kingdom, or beyond Europe to the likes of Chile, South Africa, New Zealand or China.

Thanks to our state of the art manufacturing techniques, and our in-house R&D department, we can guarantee a high quality throughout our products. **Ovlac** is determined to produce products of the highest quality, this is ingrained into our day-to-day manufacturing processes. Every step and decision taken in our company is carried out to meet our main goal: to offer our clients reliable products they can be proud of.





Novac

# MINI

## A BIG FAMILY

The **Ovlac Mini** plough is designed to combine the advantages of reduced tillage with soil inversion. Ovlac have listened to the market and utilised their 85 years of manufacturing experience to produce a plough capable of complete inversion without disturbing the soil deeper than 20cm. The result, the **Mini shallow plough**, is a specialist product enabling high work rates, low fuel consumption and excellent weed control.

Traditional ploughing is, without doubt, an ecological and efficient method of weed and disease control. However, in some situations deep ploughing unnecessarily mixes the soil layers bringing unstructured soil to the surface and burying finer topsoil. In the early days of ploughing the maximum depth was around 6" (15cm), which was ideal for keeping the fine tilth, organic matter and beneficial organisms which thrive in the top soil near the surface. Higher horsepower and annual structural damage to the soil by heavy machinery have unnecessarily led to ever deeper ploughing in some farming systems. The MINI provides the benefits of soil inversion and a weed "reset" whilst preserving the medium depth layer and dramatically increasing work rates. **The Mini achieves what a multitude of medium depth cultivators are failing to do.**

The **Mini** is an innovative development, it has been designed as a shallow plough able to cope with stubble and soil residue at limited depths (8-20 cm). This superficial inversion of the soil surface creates cavities for air and water interchange which enable quicker decomposition of organic matter, improving soil fertility and structure. The shares of the plough also break capillarity helping reduce evaporation from depth in dry periods.

Another advantage of the **Mini** shallow plough is that it works "on-land" preventing

soil compaction at the bottom of the furrow and enabling wide tyres and dual wheels to be used on the tractor for grip or to reduce compaction. This also means that all the soil that has been driven on ahead of the plough is cultivated by the MINI immediately behind the tractor.

Furthermore, ploughing at 15 cm deep requires only 1/2 of the tractor power and therefore fuel usage of ploughing 30 cm deep. Hence, the same tractor is able to plough to 40% wider with a **MINI** than a traditional plough. The Mini also cuts operational costs, it is simple and light and yet extremely robust.

### QUALITY MANUFACTURING

The **Mini** undergoes a manufacturing process with stringent quality controls, starting with the use of top quality raw materials and the most modern accurate production machinery. All critical parts are made in HEL (High Elastic Limit ) Swedish Steel. The frame, headstock and beams are all entirely welded by robots to insure consistent quality. The end result, a solid reliable **MINI**.

Furthermore, with regards to the wearing parts, the reversible points and shares are drop forged for maximum strength and endurance; mouldboards are 8 mm thick Borochrome steel and all parts are hardened and tempered to attain the best possible compromise between hardness, durability and flexibility.



 **ovlac genuine**

The quality of the original. Forged shares, 8mm mouldboards,... and always the leader's backup. Do not feel tempted by imitations.





MINI GERMANY



MINI FRANCE



“ Present all over Europe with great success ”

# CONVENTIONAL MINI

## Mini BF / HF

In Europe there are still vast regions where ploughing takes place with conventional ploughs, and not reversible. This refers mainly to Southern Europe as well to some areas in Central Europe. For this purpose Ovlac has the **Mini BF** and **Mini HF**. The former features leafspring auto-reset security system; the latter, hydraulic, with break away force regulation depending on soil conditions. Both security systems are 100% maintenance-free in order to reduce downtime to a minimum.



Mini HF



Mini BF



Mini HF body



Mini BF body



Optional hydraulic folding of rear bodies in order to reduce weight during transport or, when necessary, to work with fewer bodies



Mini HF 8+2

Just like the reversible **Mini** range, the conventional one covers three frame sizes: 6, 8 and 10 bodies. Each of these frames can be extended with the addition of one or two extra bodies, which can just be bolted on to the main frame, or hydraulically foldable, so as to reduce the total plough length and weight while road transport.



Plan view of Mini-6, Mini-8 and Mini-10 ploughs. In shaded colour, position of optional bolted-on rear wheel in contrast with the standard rear wheel.



# REVERSIBLE MINI

## Mini NF / NH

In terms of farm machinery, experience is certainly an asset. With over 20 years of experience, we can openly state that Ovlac's Mini is a reference in vast areas in Europe.

Ever since the first machines were produced back in 2003, successive improvements and innovations have been steadily implemented thanks to the feedback from farmers from more than 15 countries alongside Ovlac's experience. Ovlac listen to their customers who, as professionals, can provide invaluable indite to help improve machines.

Nowadays, the **Mini** is a shallow plough with an undisputable reputation with regards to both reliability and efficiency - its proven.



Headstock and frame support



Transport position



MINI NF 7+1  
HOLLAND



Mini NF

The last generation of the reversible **Mini**, the **Mini-N**, is available with shear bolt security for not too stony soils (**Mini NF**) or with hydraulic auto-reset system (**Mini NH**), with adjustable release pressure according to soil conditions. In hard or compacted soil, pressure can be increased in order to guarantee penetration and maintain an optimal working position of the bodies. On the contrary, under stony conditions pressure can be set lower so as not to bring out stones up to the surface. This possibility to adjust the working pressure provides great flexibility when adapting the Mini to different soil types.

The **Mini-N** range is based on 3 main frames, **Mini-N-5**, **Mini-N-7** and **Mini-N-9**, which can be extended with one or two additional bolt-on bodies each.

The 5-furrow frame is equipped with a 120 series headstock, with a 110 mm diameter shaft. 7 and 9-furrow frames come with an oversized 150 series headstock, with a solid 140 mm diameter shaft.



Mini NH



Mini-N-5

The 5-furrow frame is equipped with a 120 series headstock, with a 110mm diameter shaft. 7 and 9-furrow frames come with an oversized 150 series headstock, with a 140 mm diameter shaft

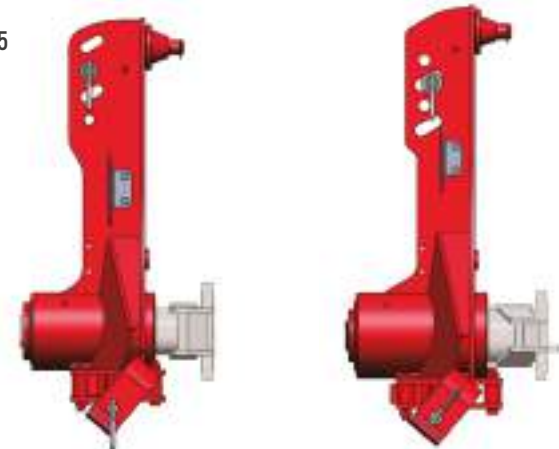

Mini-N-7/9





# REVERSIBLE MINI

## Mini NF / NH

### WHAT MAKES US UNIQUE

Ovlac **Mini** ploughs are equipped with an Oscillating Cross Shaft with a centre pivot. The plough is pulled from the centre pivot point which ensures it can move independently to follow the tractor and find the perfect balance between the side pressure exerted on the mouldboards and the landsides.

Therefore once the plough is set correctly it is not necessary to make complicated adjustments in order

to ensure the plough pulls straight. In work the plough will follow the tractor perfectly.

When lifting the plough for transport or turn over, the Oscillating Cross Shaft Alignment **automatically locks** itself in the central position.

The cross shaft movement also makes it very easy to hitch up to the plough.

In addition to the operational benefits the Oscillating Cross Shaft **significantly reduces strain on the whole plough and fuel usage.**



Oscillating cross shaft



Correction from +10° to -10°



Oscillating drawbar in action

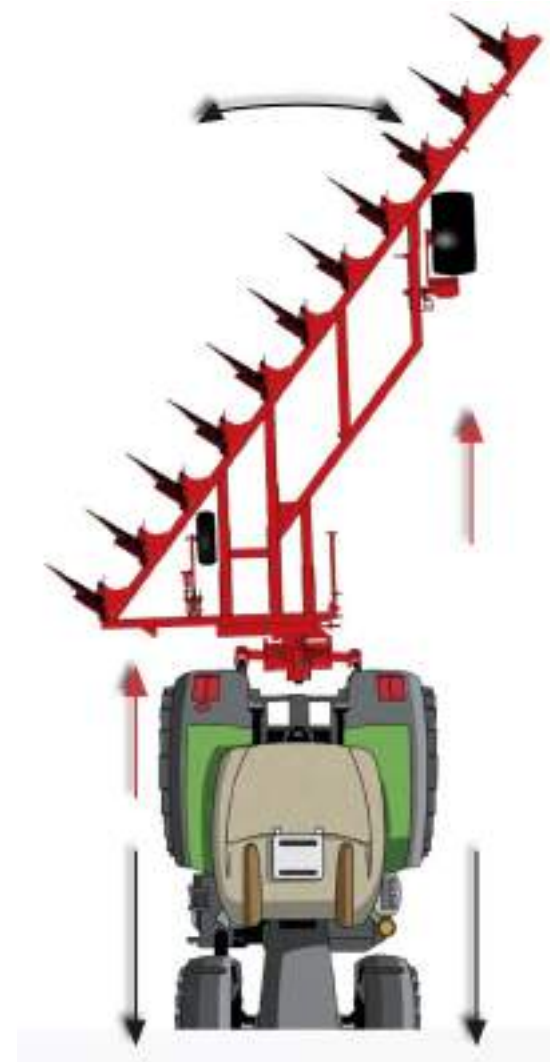



### Hydraulic adjustment of first furrow width:

The first furrow width adjustment of the Mini-N, be it mechanical or hydraulic, makes it possible to set the first furrow at the desired spot depending on the tractor width.

Once set, this width can be easily varied any time in order to get closer or further away from the furrow if the working conditions, like hills for instance, make it necessary.

The mechanical adjustment can be made using the spanner being furnished with each machine whereas the hydraulic system is adjusted by means of a double-effect hydraulic cylinder.



The sliding plates are made in 500 HEL steel to guarantee many hectares of trouble-free work even with the most demanding use.

### Auto rest protection for the most extreme conditions:

The 3D articulated security Rod linking the leg holder to the main frame has been designed to withstand the most rigorous conditions. It provides protection from sidewags force as well as enabling break-back.



# SEMIMOUNDED MINI

## Mini SF / SH



The semimounted **Mini** has been specifically developed for big states and high-power tractors. Available up to 13 furrows, the **Mini SF/SH** has a working width up to 5 m. Around, 3 ha/h can be ploughed at ease.

The **Mini SF/SH** is based upon the same frame base being used for our traditional on-land semimounted ploughs.

In order to ease the turnover of the plough at the headland, the **Mini SF/SH** features an articulation at the front which folds in the front bodies thus reducing the turnover radius and minimizing the strain on the tractor arms and headstock.



In transport





As with the mounted range, the **Mini SF/SH** is available either with shear bolt stone protection or with hydraulic auto reset system with adjustable breakaway force depending on the working conditions.

“Unrivalled performance:  
more than 3 ha/h”



# OPTIONS



Slatted mouldboards for sticky conditions-Trashboards to improve burial of trash



Extra large forged share. 12 cm longer than standard share



EcoFlow shares. Available in short or long versions. Advised for sticky soils to improve flow



"Pan- Cracker"



Landslide extension, for better plough stability



1st furrow hydraulic width adjustment



Depth control wheel. Available as 6.00\*9", 200/60, 250/65, 340/55, 280/70 y 380/55



Transport wheel available as 200/60 14,5", 250/65 14,5", 340/55 16" and 380/55 17"



Front depth control wheel available as 6.00\*9", 200/60 14,5" and 250/65 14,5"



Hydraulic depth control or combi wheel for transport and depth control



Inner depth control wheel (available for Mini-N 7 and 9 frames)



Lights kit



Headstock lock for transport



Oscillating shaft with shock absorption



## WHEEL OPTIONS

MINI-BF/HF	6 / 6+1 / 6+2		8 / 8+1 / 8+2		10 / 10+1 / 10+2	
	Front wheel	Rear wheel	Front wheel	Rear wheel	Front wheel	Rear wheel
6.00 X 9" 10 PR	-	0	0	0	0	0
200/60 14.5" 10 PR	-	X	X	X	X	X
250/65 14.5" 12 PR	-	X	-	X	-	X
340/55 16" 14 PR	-	X	-	X	-	X
380/55 17" 14 PR	-	X	-	X	-	X

MINI-NF/NH	5 / 5+1 / 5+2		7 / 7+1 / 7+2		9 / 9+1 / 9+2	
	Front wheel	Rear wheel*	Front wheel	Rear wheel*	Front wheel	Rear wheel*
6.00 X 9" 10 PR	X	-	X	-	X	-
200/60 14.5" 10 PR	-	0	X	0	X	0
250/65 14.5" 12 PR	-	X	X	X	X	X
340/55 16" 14 PR	-	X	-	X	-	X
280/70 16"	-	X**	-	X**	-	X**
380/55 17" 14 PR	-	X	-	X	-	X

MINI-SF/SH	12 / 12+1	
	Front wheel	Rear wheel*
250/65 14.5" 12PR	0	-
340/55 16" 14 PR	-	-
380/55 17" 14PR	-	-
500/50 17" 18 PR	-	0

KEY SYMBOLS	
0	Standard
X	Optional
-	Not available

\* Available as depth control or combi wheel (except for 6.00x9" 10PR)

\*\*Only available as control wheel



6.00 x 9" 10PR



200/60 14.5" 10PR



250/65 14.5" 12PR



340/55 16" 14PR



380/55 17" 14PR



280/70 16"



550/50 17" 18PR

# SUMMARY

## 3 MODELS



Conventional Mini from 6 to 12 bodies:  
**Mini-BF/HF**



Mounted reversible Mini from 5 to 11 bodies:  
**Mini-NF/NH**



Semi-mounted Mini. Available in 12 and 13 bodies: **Mini-SF/SH**

## 3 GOOD REASONS



Operating costs up to 40% lower than with a traditional plough.



Weed and disease control without the use of pesticides.

## 3 SECURITY SYSTEMS



Shear-bolt security system:  
**Mini-NF, Mini-SF**



Leafspring security system:  
**Mini-BF**



Hydraulic auto-reset system:  
**Mini-HF, Mini-NH, Mini-SH**



Optimal finish gathering the advantages of turning and the quality of minimum tillage.

# TECHNICAL FEATURES

MODEL	Working width (cm)	Recommended Power (HP)	Point to point (cm)	Underbeam clearance (cm)	Weight (kg)		
					F	H	
MINI-F	Mini 6	195	105-135		920		
	Mini 6+1	228	120-155		1.030		
	Mini 6+2	260	140-175		1.140		
	Mini 8	260	140-175		1.216		
	Mini 8+1	293	160-200	61	70	1.303	
	Mini 8+2	325	180-220			1.390	
	Mini 10	325	180-220			1.600	
	Mini 10+1	358	200-240			1.710	
	Mini 10+2	390	220-265			1.820	
MINI-N	Mini N 5	192	105-135		1.200	1.400	
	Mini N 5+1	230	120-155		1.340	1.560	
	Mini N 5+2	268	140-175		1.480	1.720	
	Mini N 7	268	140-175		1.570	1.830	
	Mini N 7+1	306	160-200	66	70	1.710	1.990
	Mini N 7+2	345	180-220			1.850	2.150
	Mini N 9	345	180-220			1.915	2.265
	Mini N 9+1	383	200-240			2.055	2.425
	Mini N 9+2	422	220-265			2.195	2.600
MINI-S	Mini NS 12	460	250-275	66	70	3.840	4.680
	Mini NS 12+1	498	260-300			3.950	4.510





## 90 YEARS OF SOIL PASSION



Conventional ploughs



Shallow ploughs



Short disc harrows



Tine cultivators



Tine cultivators for vineyards



Short disc harrows for vineyards



Polígono Industrial, P-163 / 165 - 34200 - Venta de Baños  
Palencia / Spain - Tel: **+34 979 76 10 11**  
ovlac@ovlac.com - [www.ovlac.com](http://www.ovlac.com)



FONDO EUROPEO  
DE DESARROLLO  
REGIONAL

