



Since 1936

Xperience

Innovative Tillage Technology





OVLAC

MORE THAN 85 YEARS OF EXPERIENCE

In tillage equipment

Ovlac is a **family-owned company** which has been manufacturing farming equipment **since 1936**. Since its beginnings, **Ovlac** has focused its activity in manufacturing **mouldboard ploughs**, which have been the company's flagship product for decades and still is today.

Over the last 15 years, the **Ovlac** product range has expanded to include other soil working tools such as **Cultivators, Chisels** and **Short Disc Harrows**. Today, Ovlac is being run by its third generation and its **the biggest Spanish soil working equipment manufacturer**.

Ovlac exports around 60% of its production to more than **20 countries**.

Competitive and demanding markets such as France, Germany and the United Kingdom, or **beyond Europe** to the likes of Chile, South Africa, New Zealand or China.

Thanks to our **state of the art manufacturing techniques**, and our **in-house R&D department**, we can guarantee a high quality throughout our products. **Ovlac** is determined to produce products of the highest quality, this is ingrained into our day-to-day manufacturing processes. Every step and decision taken in our company is carried out to meet our main goal: to offer our clients reliable products they can be proud of.



RANGE: THE RIGHT MODEL TO FIT YOUR TRACTOR

Ovlac's range of **XPerience** reversible ploughs is made up of 3 series, 3 ranges, so you can always find the ideal solution to suit your available power and soil conditions.

SERIES 130

Featuring a substantial 140 mm diameter headstock shaft. This series is available in a 4 or 5 furrow configuration, and is rated up to 200 HP (150 kW). At the same time, it keeps the 100 by 150 mm frame section of the 120 Series to stay light.

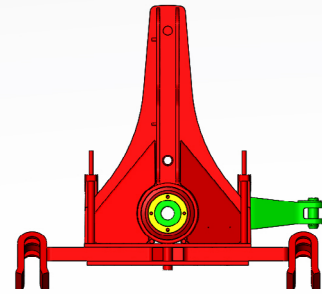

Headstock 130.

SERIES 150

Higher Strength available as 4 and 5 furrow configurations designed for arduous conditions and higher horse power. Rated up to 225 HP (165 kW). 150 by 150 mm frame section and reinforced headstock with a 140 mm shaft diameter.

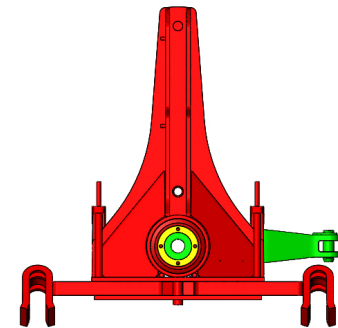

Headstock 150/180.

SERIES 180

The Pinnacle in the mounted range available as 5 and 6 furrow configurations. With a superstructure design consisting of 150 by 150 mm frame section, heat treated 140 mm headstock, substantial reinforced Hardox supports and larger turnover ram. This range topping mounted plough is capable of remarkably high work rates. Rated up to 285 HP (210 kW)



**SERIES
130**

Headstock 130 + frame support 130
+ frame section 150*100.

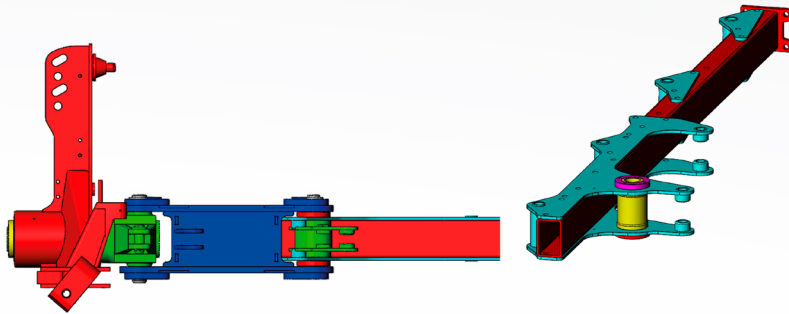

**SERIES
150**

Headstock 150 + frame support 150
+ frame section 150*150.

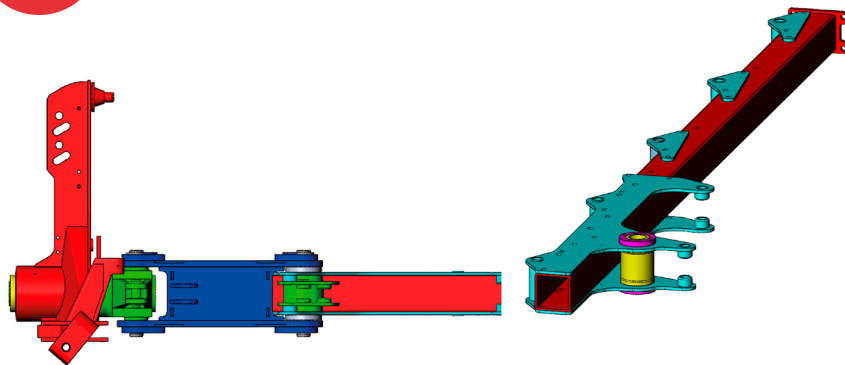

**SERIES
180**

Headstock 180 + frame support 180
+ frame section 150*150.

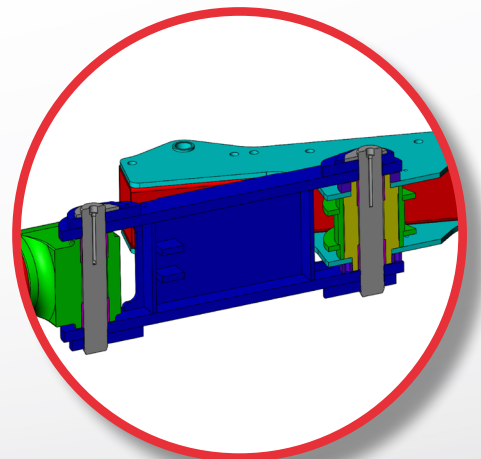
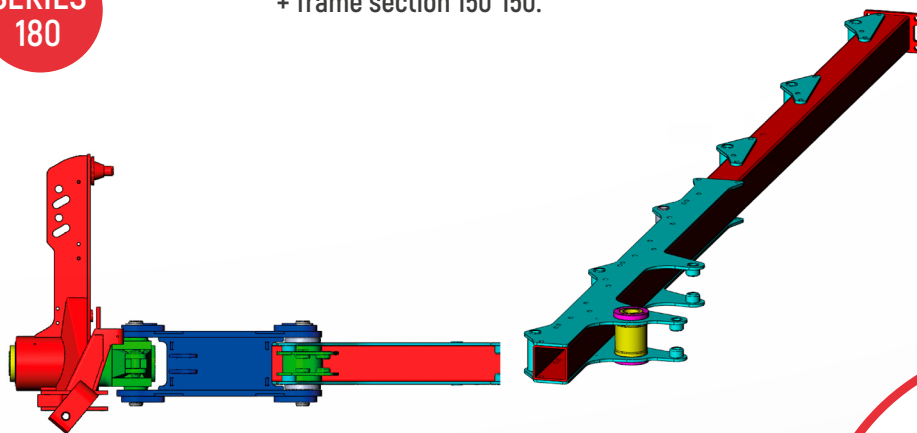

PROTECTION SYSTEMS

Shear bolt and hydraulic

Taking into account working conditions, **Ovlac XPerience** ploughs can be equipped with two different protection systems.

SHEAR-BOLT SECURITY SYSTEM:

The simplest of all two. The shear bolt thickness, steel grade and position are calculated so it breaks under a pressure of approx. 3000 kg exerted at the point. It is highly recommended that broken shear bolts be replaced by genuine ones; a non-genuine shear bolt, bearing a different dimension or steel grade can result in serious damage to the main plough frame for not correctly accomplishing its task.

Shear bolt



HYDRAULIC NON-STOP SYSTEM:

Regulated trip mechanism. It allows for adapting release pressure according to soil conditions. In heavy or compacted soil, pressure can be increased in order to guarantee penetration and maintain an optimal working position of the bodies. On the contrary, under stony conditions pressure can be set lower in order not to bring stones onto the surface. Frog legs are also bolted on to the beam, and not welded thus benefitting from dual security.

Hydraulic



VARIABLE WORKING WIDTH

"XP" Model - "XP-V" Model

Working width adjustment is available in all **Ovlac XPerience** ploughs in order to adapt the plough to soil conditions or the desired work.

Working width of all **"XP" models** (XPF y XPH) can be manually adjusted by simply shifting positions of the support bolt into a different hole on the beam. There are **four different working widths with 2 inch increment adjustments**.

All **"XP-V" models** (XPFV y XPHV) come with the well known Ovlac Varilabor variable working width as standard. Working width can be **hydraulically operated from the tractor cab** between 12 and 20 inches per body (can slightly change depending on different models). This feature provides several advantages:

- **Optimized output**, making the most out of the tractor power.
- **Adaptation to desired work** in terms of working depth, soil type, crop types and seasons.
- **Adaptation to ploughing plot individualities:** topography and obstructions.

Automatic Memory System: the complete range of **Ovlac XPerience** reversible ploughs in 5 and 6 furrows comes as standard with an automatic memory system which withdraws the plough main frame to its minimum width so as **to guarantee a gentle turning over** and avoid that the rear end of the plough hitting the ground. Once this operation is done, the plough automatically returns to the originally set working width.

"XP" Models



"XP-V" Models

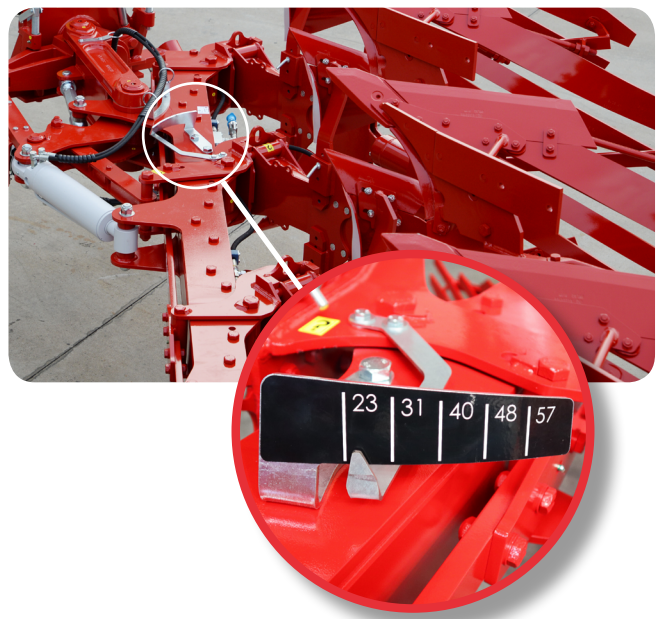

WHAT MAKE US UNIQUE

Oscilating drawbar. Automatic self-alignment

1 - OSCILATING DRAWBAR. AUTOMATIC SELF-ALIGNEMENT

Ovlac XPerience reversible ploughs can be equipped with the Oscillating Hitch makes it possible for the **plough to move freely from a central pivoting point** in the cross-shaft and to find by itself the perfect balance between the side pressure exerted on the mouldboard and the landslide.

Therefore it is no longer necessary to adopt complicated adjustments in order to regulate the draw line so as to make the plough work perfectly aligned.

Alignment is automatically corrected with no need of any operation by the operator.

In the Hydraulic Vari width ploughs the Oscillating Hitch makes it possible for the plough to adjust itself to the new pressure balance resulting from modifying working widths, correcting automatically and immediately the ploughs alignment, with no effort required by the operator. It cannot be simpler.

When lifting the plough up for transport or turning over, the Oscillating Hitch **will automatically lock** itself preventing the plough from balancing sideways.

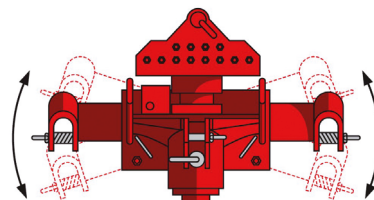

Other ploughs

Ovlac Ploughs

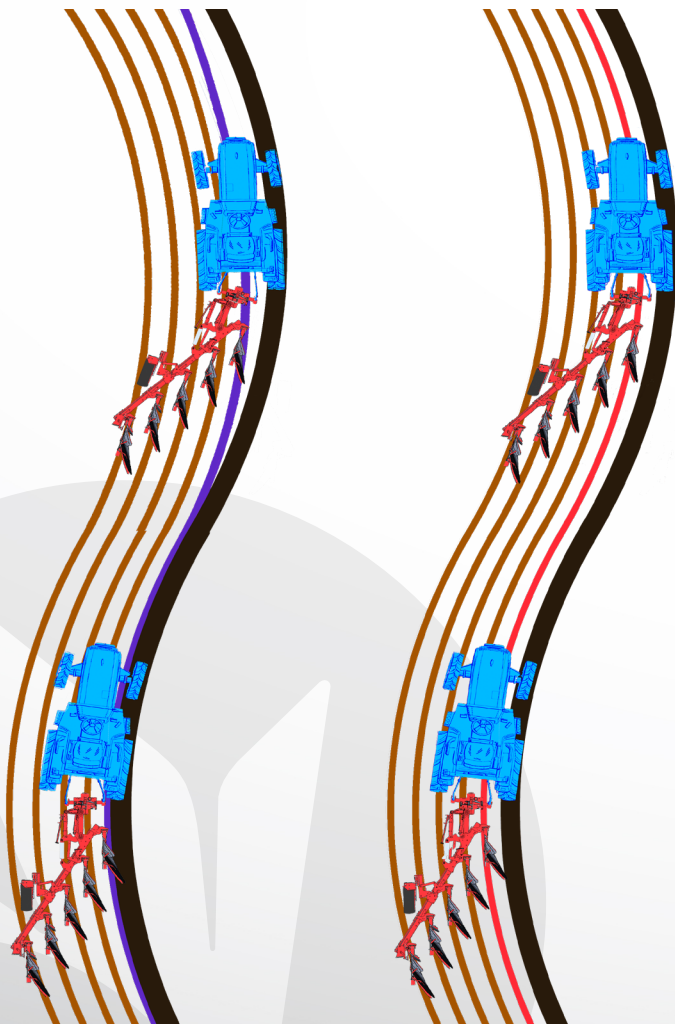

Oscillating Drawbar in action

OTHER STRONG OPTIONS

Frames, Non Stop systems, Vari width

2 - SUBSTANTIAL SIMPLE AND RELIABLE MAIN BEAM

The main beam is made in high quality steel, and is **100% free from welding**. Therefore tensions and weak spots are eliminated. Furthermore, in its forefront, the area where efforts are biggest, the frame is reinforced with "Hardox sandwich" plates.

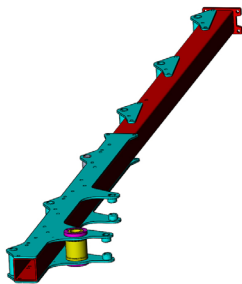

3 - LONGEVITY DESIGNED IN

In hydraulic vari width models (XPV), body supports are bolted onto the frame; thus, in the case of an improbable breakdown, these supports are easily replaceable.

Furthermore, the pivoting points of these supports are located away from the main frame, this way the frame is not weakened or subject to any wear. These pivoting points are equipped with wear resistant case-hardened bushes and greasing points in order to ensure a long lifespan.

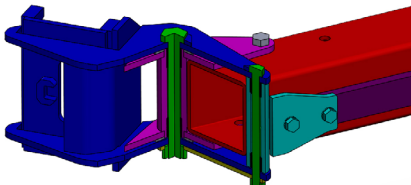

4 - NON STOP PLOUGHS FOR THE HARDEST CONDITIONS

In Hydraulic non-stop Ploughs, frog beams/legs are bolted instead of welded. One of the fixing bolts is specifically designed as a shear bolt, which results in an extra security to be added to the Non Stop



The Articulated Security Rod linking the leg holder to the main frame has been designed to withstand the most rigorous conditions. Its articulated system results in a genuine 3D security system.

5 - EXPERIENCE AND MODERNITY

Ovlac has over 80 years of experience in the manufacturing of ploughs. This practical knowledge is supplemented up by the efforts of a young team of capable engineers using the latest design, development and production techniques in order to attain the perfect combination of experience and modernity.

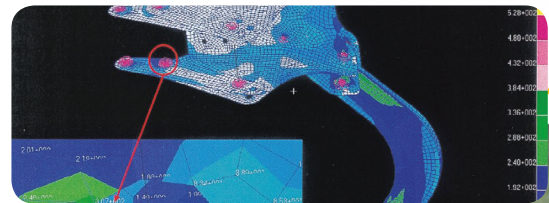

XPERIENCE ON-LAND

The On land version of the best plough

XPerience On Land (XP-OL) is the next step in the evolution of the XP design, adapted to work both in-the-furrow or on-land. This is the result of several years of research since the launch of the first XP, as well as the incorporation of all our expertise in the design of soil working equipment.

The most significant change on this model is an oversized parallelogram with 2 cylinders. The first of these cylinders controls the width of the first body (in the furrow or on land), as well as closing in the plough for a gentle, trouble-free turning. The second cylinder controls the working width. Changing position from in the furrow to on-land is as simple as opening or closing a valve, with no need for any tools.



Working on-land becomes necessary with large or twin wheel tractors. Thus the XP-OL allows to work with tractors up to 3.20 metres wide.

Another very important point to consider is the possibility to work with GPS auto-steering systems. Agronomically, working on land has a series of advantages, such as less compaction at the bottom of the furrow, as well as gaining better traction thus reducing fuel consumption and CO2 emissions.



TECHNICAL FEATURES

S Shearbolt

H Hydraulic

	N° of bodies	4-EXT		5		5-EXT		5-EXT-OL		6		6-OL		6+1-OL	
		Security	F	H	F	H	F	H	F	H	F	H	F	H	
SERIES 130	Working width [XP/XPV]	140-200 / 120/200		175-250 / 150-250											
	Interbody clearance (cm)	85 95 105	85 95	85 95 105	85 95										
	Under beam clearance (cm)	72 78 90	72 78	72 78											
	Weight [XP/XPV]	1585 1665	1680 1760	1755 1855	1915 2015										
	Power [HP]	120-160		150-180											
SERIES 150	Working width [XP/XPV]	140-200 / 120/200		175-250 / 150-250											
	Interbody clearance (cm)	85 95 105	85 95	85 95 105	85 95										
	Under beam clearance (cm)	72 78	72 78	72 78											
	Weight [XP/XPV]	1670 1750	1795 1875	1850 1950	2050 2150										
	Power [HP]	120-180		150-225											
SERIES 180	Working width [XP/XPV]					175-250 / 150-250		175-250 / 150-255		210-300 / 180-300		210-300 / 180-306		245-350 / 210-350	
	Interbody clearance (cm)					85 95 105		85 95 105	85 95	85 95		85 95 95		85 95	
	Under beam clearance (cm)					72 78 90	72 78	72 78		72 78		72 78		72 78	
	Weight [XP/XPV]					1860 1960	2150 2250	2050 2150	2340 2440	2040 2160	2405 2525	2230 2350	2595 2715	2580 2700	
	Power [HP]					150-250		175-200		180-300		210-300		245-350	

Vario	Mechanic	Hydraulic	Mechanic	Hydraulic
180 CV	XPF 130	XPVF 130	XPH 130	XPVH 130
225 CV	XPF 150	XPVF 150	XPH 150	XPVH 150
285 CV	XPF 180	XPVF 180	XPH 180	XPVH 180

BODIES

Range of 5 plough bodies

Ovlac has 5 different plough bodies in order to offer the most suitable option for a specific ploughing technique and soil. All genuine Ovlac mouldboards (with the exception of the slatted and plastic boards) are made in 8 mm thickness and undergo a **unique Case - Hardening process** in order to **achieve over HRc 62 on their surface** while still offering a soft core. Apart from guaranteeing a long lifespan of the mouldboard, case-hardening also results in less sticking and better soil flow.

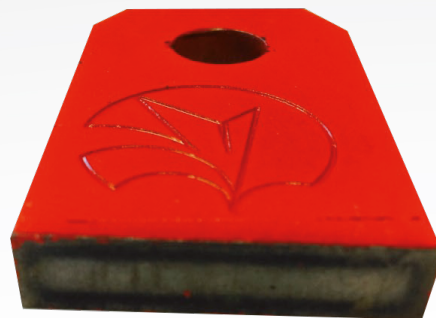

Case-hardening allows for higher hardness on surface, more than 62 HRc, while keeping a soft, flexible core.

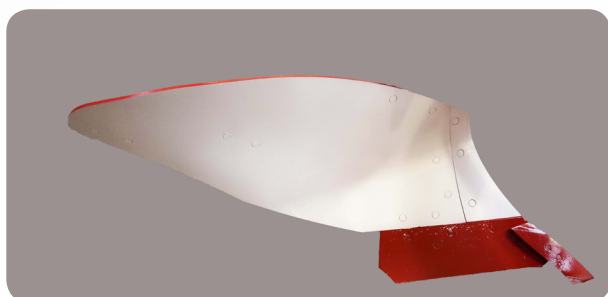

V-34: all-purpose body for all types of soil. Good soil turning with limited tractor power requirements. For depths between 15 and 35 cm.

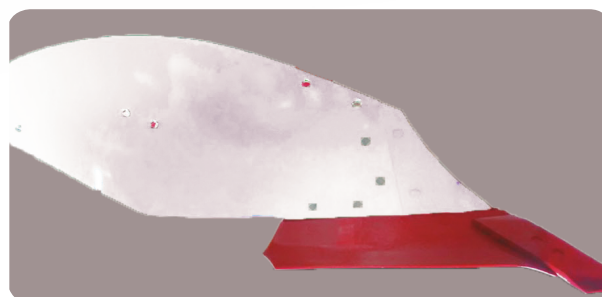

V-97: all-purpose body for all soil types. Very low tractor power requirement. Working depth between 15 and 30 cm.

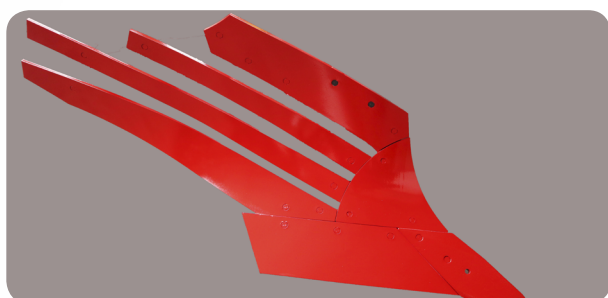

V-LOV: mouldboard with slats. Suitable for sticky soils. All wearing parts mounted with conical bolts in order to lengthen lifespan, specially of slats.

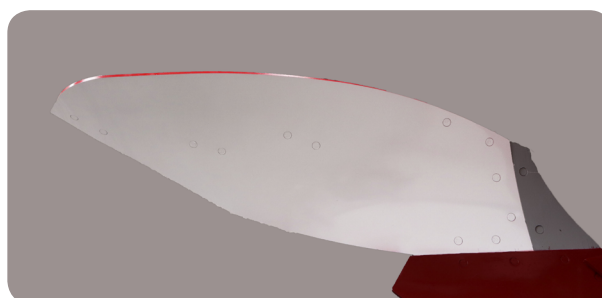

V-90: leaves a wide furrow; specially recommended for very wide tractor tyres (>760 mm). Very good soil turning thanks to its extra length. Similar power requirement to body V-97.

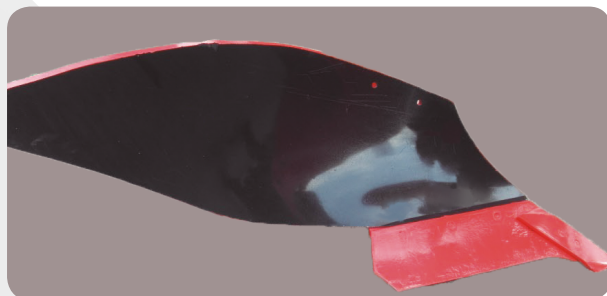

V-PLAST: recommended for very sticky soils with no stones. Same geometry as V-34 body.

OPTIONS

Wide range of accesories

A wide range of accessories is available in order to adapt the plough to any working type and soil.



Trashboard

Three skim mouldboards available: Grass and High Capacity. It is important that Skimmers are correctly set in height. That is why we have designed them so no tools are needed to this end.



Smooth or Notched Coulter Discs with Non Stop Security System.



Coulter Discs. Either Smooth or Notched. 18 or 20 inch.

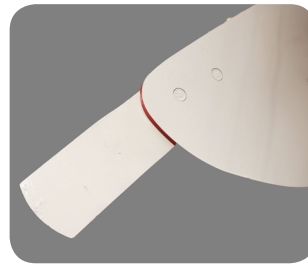

Tailpress

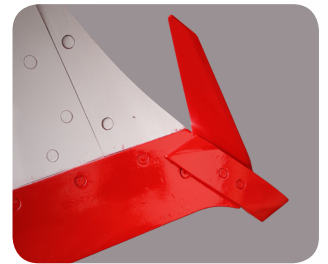

Share knife.

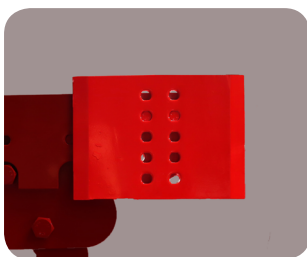

Landslide extension.

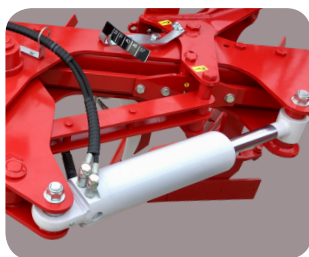

Memory cylinder.

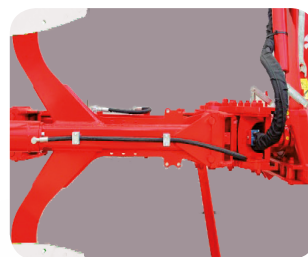

X-Light beam, 25 kg lighter than standard one (Max: 32 HP per body). Available solely for 130 series.

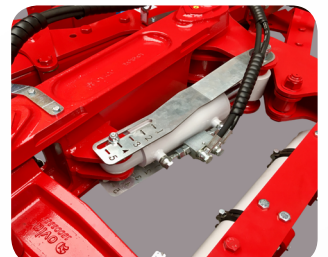

Hydraulic Front Furrow Width Adjustment.

WHEELS

A large range to meet any need

We have the perfect wheel for your needs.

Ovlac XPerience reversible ploughs can be equipped with very different wheel types:

As regards its function, there are **Depth Control Wheels** and **Combi Wheels**, both for depth control and transport. As regards their position, we have either Rear or Advanced Wheels. **Rear Wheels** assure an optimal plough balance as well as better weight transfer to the tractor while ploughing.

In turn, **Advanced Wheels** are advisable when trying to get closer to field borders. Advanced Wheels also result in less strain on tractor arms when in transport or when turning the plough over as the centre of the gravity is closer to the tractor.

Several wheel sizes and types of wheels are available to suit your requirements.



Rear depth control wheel 550/65.



Rear depth and transport wheel 250.



Rear depth control wheel 250.



Advanced depth control wheel 250.



Advanced depth and transport wheel 340.



Hydraulic depth control wheel 280/70.



In Mode1 Ovlac's hydraulic wheel allows for gradual start and finish at the headland



In Mode2 Ovlac's hydraulic wheel allows for Depth control on the edge of the field.

OTHER PRODUCTS

In the Ovlac range



CONVENTIONAL PLOUGHS



SEMI-MOUNTED PLOUGHS



MINI



MINI N



MINI S



MINICHISEL VINEYARD



XLANDER



VERSATILL



HC LINE



MAXIDISC II



EURODISC



MINIVID



REPTILL



A SOLUTION FOR ANY FIELD



Polígono Industrial, C/ TAF, P163
34200 - Venta de Baños
Palencia - España



+34 979 76 10 11



comercial@ovlac.com



www.ovlac.com



FONDO EUROPEO
DE DESARROLLO
REGIONAL



UNION EUROPEA

